

# VALVE MODEL #2260

## NORMALLY OPEN PRESSURE REDUCING VALVE

October, 1993

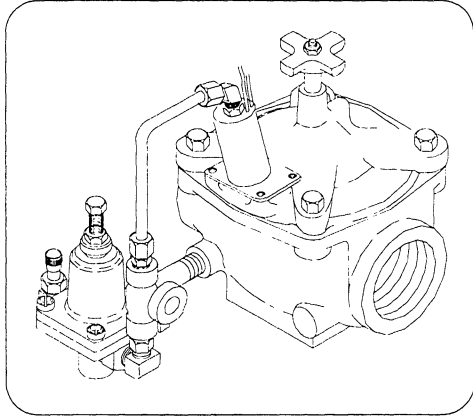

MODEL # 2260

For the above valves, use a Basic 2160 and these parts

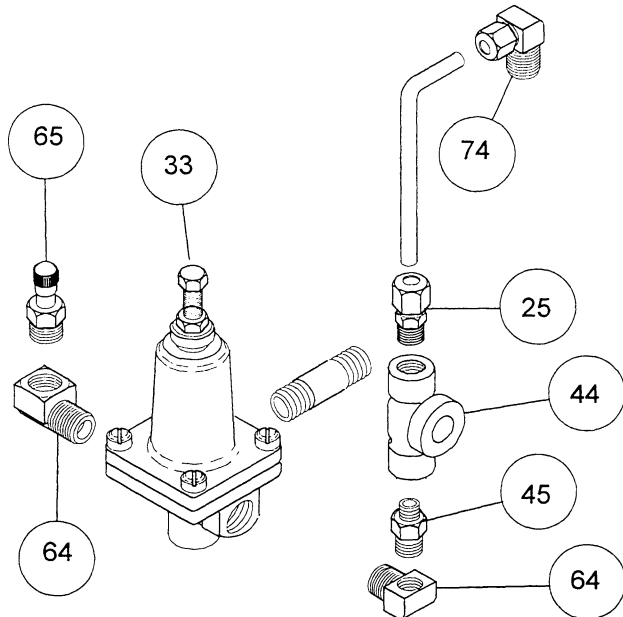

### INSTALLATION AND MAINTENANCE

- 1 Inlet pipe plug installed for straight pattern installation, for angle installation, re-install plug
- 2 Flow direction must be as indicated on nameplate
- 3 Valve must have minimum inlet pressure of 2 PSI (5 feet) If lower inlet pressure is required, consult factory
- 4 Valve can be installed in any position
- 5 Valve can be repaired without removing valve body from system
- 6 To adjust downstream pressure adjust screw on regulator, part #33 To increase pressure turn adjustment screw clockwise To decrease pressure turn adjustment screw counter clockwise
- 7 Valve can be closed manually with manual on-off pilot (item #44)
- 8 No normal maintenance is required

### TROUBLE SHOOTING

PROBLEM	PROBABLE CAUSE	CORRECTION
1 Downstream pressure too low	Installed backwards	Check flow arrow
	Lack of operating pressure	Make sure inlet is 2 PSI minimum
	Optional manual flow adjustment stem fully closed	Open stem
	External obstruction in line, such as closed gate valve, etc	Check other system elements
	Internal foreign matter	Remove cover, clean valve thoroughly
	Restriction in copper tube, such as ends not de-burred or bend in tube	Repair problem
2 Downstream pressure too high	If after long satisfactory service, check diaphragm assy wear	Eliminate other causes then replace assy
	Ruptured diaphragm	Replace diaphragm
	Internal foreign matter	Remove cover, clean valve thoroughly
	Cover spring left out	Add cover spring
	Leak in control line	check for leaks and repair



2803 Barranca Parkway, P.O. Box 19612, Irvine, CA 92714  
(714) 559-6000, FAX: (714) 559-6088

F-2763A

## MODEL 2260

The Griswold Model 2260 valve consists of (1) a main valve, (2) a pressure regulating pilot, (3) a manual on-off pilot, and (4) a Schraeder valve to allow for downstream pressure measurement

The 2260 valve is a normally open solenoid valve. With its manual on-off pilot in the open position, the main valve remains open and supplies a constant downstream pressure with fluctuating or excessive downstream pressure. Desired downstream pressure may be set anywhere from 5 to 125 PSI

These valves can be shut off by turning (clockwise) their manual on-off pilot valve

### REQUIRED TOOLS TO SET THE VALVE:

- 1 Adjustable or 1/2" open, box or socket wrench
- 2 0-150 psi gauge equipped with quick-connect fitting for attachment to tire type (Schraeder) valve

### TO SET THE VALVE:

1. Remove the cap from the Schraeder valve
- 2 Attach the gauge kit to the Schraeder valve
- 3 Make sure that the manual on-off pilot valve is wide open by turning its handle counter clockwise all the way
- 4 Open a valve downstream of the 2260 valve to allow water to flow. If no flow occurs check for valves shut off upstream
- 5 With water flowing through the valve, turn the adjusting screw on the regulating pilot until desired downstream pressure is observed on the gauge. Turning the adjusting screw "in" (clockwise) increases pressure; "out" (counter-clockwise) decreases pressure.

**NOTE:** If turning the adjusting stem clockwise does not increase downstream pressure, upstream pressure may be too low. Check upstream pressure under flowing conditions.

- 6 Disconnect gauge kit, place cap back on the Schraeder valve. The 2260 valve is now set for normal operation

