

SPECIFICATIONS:

PSI / Temperature Rating: 150 PSI / 275° F
Cartridge: AISI Type 304 stainless steel
 AISI Type 17-7 PH stainless steel spring
Body Material: Ductile Iron ASTM A536-80
 Class 50-40-18
End Connections: ANSI 150 Lb. Flanges 2-1/2 and 3 Inch
Seals: EPDM O-Rings
Body Tappings: 1/4" NPT with P/T test valves
Assembly: Valve comes fully assembled
Options: Extended P/Ts
Isolation Options: Butterfly Valve

FLOW RATES (±5%)

SIZE ¹	MODEL NO.	HEAD LOSS IN FEET ²	PSID RANGE	GPM		
				MIN	INCREMENT	MAX
2-1/2", 3"	3UF1_B_	3.5	1-14	12.0	2.0	114.0
	3UF2_B_	7.4	2-32	18.0	3.0	171.0
	3UF4_B_	13.4	4-57	24.0	4.0	228.0
	3UF8_B_	30.0	8-128	36.0	6.0	342.0

DIMENSIONS & WEIGHTS (NOMINAL)

SIZE	MODEL NO.	A HEIGHT	B HEIGHT	C LENGTH	Cv ³	WEIGHT (LBS.)
2-1/2", 3"	3UF_B_	5.3	4.3	11.9	119	28

MODEL NUMBER SELECTION⁴

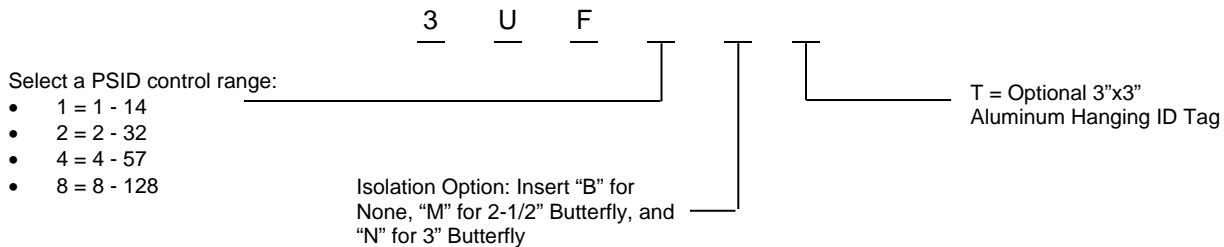

NOTES

- ¹ 2" Reducing flanges can be used. Consult your local pipe fitting supply house or contact the factory for assistance.
- ² Head Loss in Feet is provided for pump head calculations. (1 PSI = 2.307 Feet of Water)
- ³ Cv measured without cartridge
- ⁴ Model no. and flow rate are indicated on label affixed to body

Replaces form F-4205

This specification © 2015 Griswold Controls

2803 Barranca Parkway, Irvine, CA 92606
 (949) 559-6000 Fax (949) 559-6088
 www.GriswoldControls.com



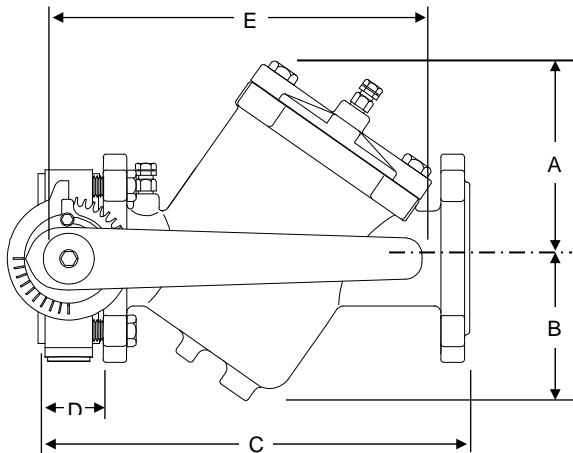

SPECIFICATIONS:

PSI / Temperature Rating: 150 PSI / 275° F
Cartridge: AISI Type 304 stainless steel
 AISI Type 17-7 PH stainless steel spring
Body Material: Ductile Iron ASTM A536-80
 Class 50-40-18
Butterfly Valve: Iron ASTM 126-61T Class 30, NBR
 Seat, ductile disc, stainless steel stem
End Connections: ANSI 150 Lb. Flanges 2-1/2" and 3"
Seals: EPDM O-Rings
Body Tappings: 1/4" NPT with P/T test valves
Assembly: Valve comes fully assembled
Options: Extended P/Ts

DIMENSIONS & WEIGHTS (NOMINAL)

SIZE	MODEL NO.	A HEIGHT	B HEIGHT	C LENGTH	D	E	Cv ⁵	WEIGHT (LBS.)
2-1/2"	3UF_M_	5.3	4.3	13.6	1.8	10.7	119	40
3"	3UF_N_							

OPTIONS:

- 2-1/2" - 3": two 1/4" by 1-1/4" PT extensions (Part Number 9666-110)

NOTES

⁵ Cv measured without cartridge

Replaces form F-4205

This specification © 2015 Griswold Controls

2803 Barranca Parkway, Irvine, CA 92606
 (949) 559-6000 Fax (949) 559-6088
 www.GriswoldControls.com