

“How Do I Choose a Cartridge?”

HVAC TERMINAL UNIT APPLICATIONS

Griswold Controls offers four different PSID ranges for our cartridges, because with precision comes accuracy. Our cartridges stay within their 5% tolerance over their precise flow range. Other companies have much larger PSID ranges, but cannot match the accuracy of the Griswold Automatic Flow Cartridge.



To select which PSID Range is right for your Terminal Unit application, follow these guidelines:

- 1. Available Line Pressure:** Total pressure for the line must be known (If unavailable proceed directly to Step 4b). For a multiple branch system, consider each branch separately, and use the pressure differential across the entire branch. You need to ensure that the correct PSID range is selected for the branch nearest the pump and for the branch farthest from the pump (index circuit). If both of these circuits call for the same PSID range, all the circuits in-between will use that same PSID range.
- 2. Component Pressure Drop:** Calculate all of the pressure drops across the branch – for example, coils, long pipe-lines and any other components and fittings that cause constant amounts of pressure drop. Some components have a best and worst case pressure spec, as in the case of a strainer whose pressure drop may vary depending on the cleanliness of the strainer, or a throttling valve. If you have the total pressure for the branch and the components are Griswold Controls CPP components, Griswold can calculate pressure for those components. If pressure information for a coil is unknown, estimate 3 to 5 PSID.
- 3. Calculation:** Ensure that all pressure calculations are converted to PSI (1 PSID = 2.307 feet of head). Subtract the total pressure drop (Step 2) from the total system or branch pressure (Step 1) to arrive at the total pressure available for the cartridge.
- 4. PSID Range:** That number (or numbers in best/worst systems) is the pressure that determines the required PSID range for your cartridge. If there are two acceptable PSID ranges, pick the lower range because there are always small pressure drops (for fittings, etc) that we neglect and that may be discovered after the system is functioning. Also, it is recommended that you pick a range which situates your PSID roughly in the middle of the range.

4b. No Information? If no information is available, 2–32 PSID is proven to match most HVAC applications.

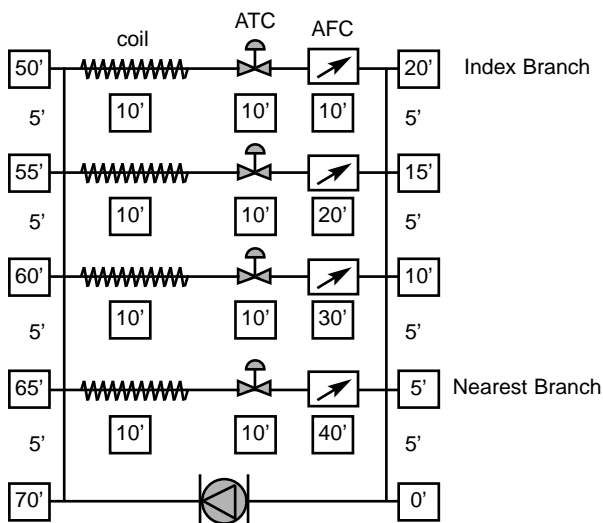

Example – Multiple Branch,
Constant Speed System

General Rule for PSID ranges: for a system with up to 75' Pump Head, you will generally need a 2–32 PSID cartridge. More than 75', some branches may require 4–57 PSID. The 8–128 PSID range is not usually used for HVAC.

In the example at left, the total component pressure drop across the first branch is 60' (or about 22 PSID). The farthest (or index) branch has a drop of 30' (or about 13 PSID). The values shown for the components in the example are nominal.