

SPECIFICATIONS

PSI/Temperature Rating

Metering Station:

QuickSet:

Low Loss Venturi:

Body Material:

Butterfly Valve¹:

End Connections:

Body Tappings:

Installation:

400 PSI/250° F

200 PSI (14"-18": 150 PSI) /250° F

Carbon Steel with Piezo-Ring to average low signal pickup

Carbon Steel SA-53 Grade B

Bronze disk, S.S. stem

Grooved End

1/4" NPT with Brass P/T test valves

No straight-run is necessary for normal operation.

Consult chart (F-4439) for exact Flow Constant and Permanent Pressure Drop calculations.

QuickSet (2-1/2"-6")

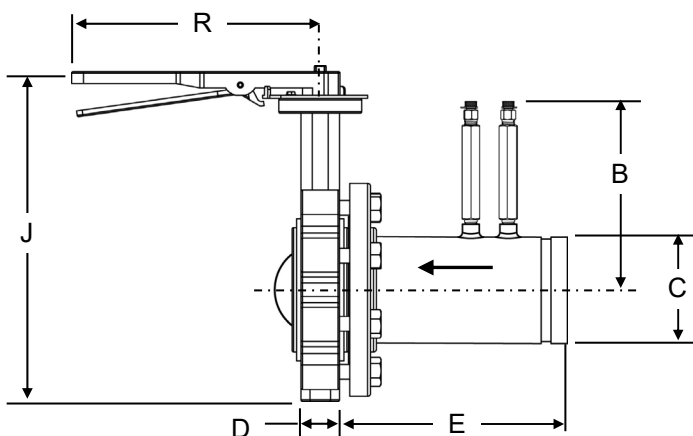

QuickSet (8"-18")

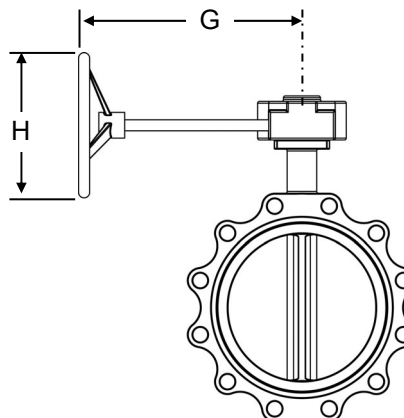

DIMENSIONS & WEIGHTS FOR QUICKSET (NOMINAL)

All dimensions are for planning purposes only and may change without notice.

LINE SIZE	B	C	D	E	G	H	J	R HANDLE	WEIGHT (LBS.)	
									W/ HANDLE	W/GEAR WHEEL
2-1/2"	7.3	2.9	1.8	6.0	N/A	N/A	11.6	10.5	10.5	N/A
3"	7.6	3.5	1.8	6.5	N/A	N/A	12.1	10.5	13.1	N/A
4"	8.0	4.5	2.0	8.1	N/A	N/A	13.6	10.5	19.7	N/A
5"	8.6	5.6	2.1	10.0	N/A	N/A	14.6	10.5	26.6	N/A
6"	9.1	6.6	2.3	11.5	N/A	N/A	15.6	10.5	36.5	N/A
8"	10.1	8.6	2.4	15.0	9.5	12.0	18.9	N/A	N/A	65.5
10"	11.2	10.8	2.6	18.0	9.5	12.0	21.3	N/A	N/A	101.9
12"	12.2	12.8	3.0	21.5	9.5	12.0	24.6	N/A	N/A	157.8
14"	12.8	14.0	3.0	24.0	9.5	12.0	26.8	N/A	N/A	208.5
16"	13.8	16.0	4.0	27.5	15.0	16.0	30.0	N/A	N/A	257.0
18"	14.8	18.0	4.5	31.8	15.0	16.0	31.6	N/A	N/A	311.2

NOTES

¹ Butterfly valve is standard on QuickSet only.

DIMENSIONS & WEIGHTS FOR METERING STATIONS (NOMINAL)

All dimensions are for planning purposes only and may change without notice.

LINE SIZE	A	B	C	WEIGHT (LBS.)
2-1/2"	5.8	7.3	2.9	3.1
3"	6.3	7.5	3.5	4.4
4"	7.9	8.0	4.5	7.9
5"	9.8	8.6	5.6	13.3
6"	10.3	9.1	6.6	18.1
8"	12.3	10.1	8.6	32.5
10"	15.5	11.2	10.8	57.7
12"	16.5	12.2	12.8	79.4
14"	16.5	12.8	14.0	95.0
16"	17.5	13.8	16.0	111.2
18"	16.8	14.8	18.0	120.5

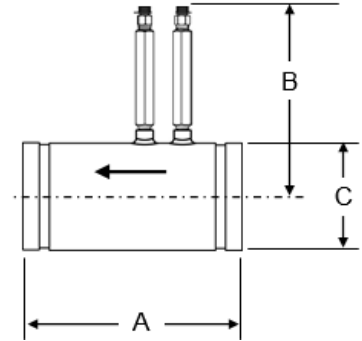

FLOW RATES (+/-1%²)

LINE SIZE	MODEL NO.	Cv Metering Station ³	Cv Quickset ³	GPM RANGE FOR 5"-100" ⁴ W.C. ΔP (SET W/100" GAUGE)	GPM RANGE FOR 5"-300" W.C. ΔP (SET W/300" GAUGE)
2-1/2"	3QGM	171	135	19 – 87	19 – 151
3"	3QGN	269	201	32 - 147	32 – 255
4"	3QGP	580	417	58 – 260	58 – 451
5"	3QGQ	800	630	80 – 372	80 – 645
6"	3QGR	1250	980	140 – 624	140 – 1075
8"	3QGS	2100	1745	260 – 1180	260 – 2045
10"	3QGT	4000	3201	375 – 1610	375 – 2790
12"	3QGU	5700	4690	600 – 2790	600 – 4820
14"	3QGV	7300	6225	775 – 3420	775 – 5940
16"	3QGW	9600	8283	1250 – 5525	1250 – 9575
18"	3QGX	14500	12057	1650 – 7405	1650 - 12830

MODEL NUMBER SELECTION

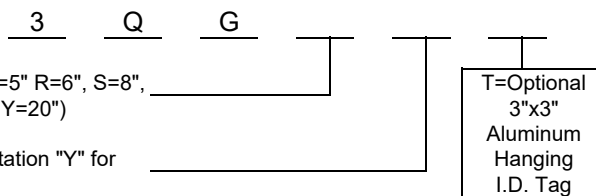

Select a Size (M=2.5", N=3", P=4", Q=5" R=6", S=8", T=10", U=12", V=14", W=16", X=18", Y=20")

Select Valve Style ("0" for Metering Station "Y" for QuickSet with Butterfly Valve)

NOTES

² Accuracy is for venturi portion of valve only. Pressure readability is dependent on accuracy of gauge and system pressure stability.

³ Cv's are used to calculate permanent pressure drop. $PSID=(Flow/Cv)^2$. Consult chart F-4439 for flow measurement.

⁴ Not all gages/meters can accurately show a 5" signal. Readability is dependent on quality of the meter. Digital gages can read below 1".